

SIEMENS EDA



Importing and Simulating a SPICE Model File

2023.10

Unpublished work. © 2022 Siemens

This software or file (the "Material") contains trade secrets or otherwise confidential information owned by Siemens Industry Software Inc. or its affiliates (collectively, "SISW"), or SISW's licensors. Access to and use of this information is strictly limited as set forth in one or more applicable agreement(s) with SISW. This Material may not be copied, distributed, or otherwise disclosed without the express written permission of SISW, and may not be used in any way not expressly authorized by SISW.

Unless otherwise agreed in writing, SISW has no obligation to support or otherwise maintain this Material. No representation or other affirmation of fact herein shall be deemed to be a warranty or give rise to any liability of SISW whatsoever.

SISW reserves the right to make changes in specifications and other information contained herein without prior notice, and the reader should, in all cases, consult SISW to determine whether any changes have been made.

SISW MAKES NO WARRANTY OF ANY KIND WITH REGARD TO THIS MATERIAL INCLUDING, BUT NOT LIMITED TO, THE IMPLIED WARRANTIES OF MERCHANTABILITY, FITNESS FOR A PARTICULAR PURPOSE, AND NON-INFRINGEMENT OF INTELLECTUAL PROPERTY. SISW SHALL NOT BE LIABLE FOR ANY DIRECT, INDIRECT, INCIDENTAL, CONSEQUENTIAL OR PUNITIVE DAMAGES, LOST DATA OR PROFITS, EVEN IF SUCH DAMAGES WERE FORESEEABLE, ARISING OUT OF OR RELATED TO THIS PUBLICATION OR THE INFORMATION CONTAINED IN IT, EVEN IF SISW HAS BEEN ADVISED OF THE POSSIBILITY OF SUCH DAMAGES.

TRADEMARKS: The trademarks, logos, and service marks (collectively, "Marks") used herein are the property of Siemens AG, SISW, or their affiliates (collectively, "Siemens") or other parties. No one is permitted to use these Marks without the prior written consent of Siemens or the owner of the Marks, as applicable. The use herein of third party Marks is not an attempt to indicate Siemens as a source of a product, but is intended to indicate a product from, or associated with, a particular third party. A list of Siemens' Marks may be viewed at:

www.plm.automation.siemens.com/global/en/legal/trademarks.html

Support Center: support.sw.siemens.com

Send Feedback on Documentation: support.sw.siemens.com/doc_feedback_form

Table of Contents

Support Kit.....	2
Objective.....	2
Included Files.....	2
Description.....	2
Directions.....	3
Conclusion.....	8

Objective

Abstract:

In this article we will go over how to simulate an imported SPICE Model file with HyperLynx AMS.

At the end of this lab, you will be able to:

- Import a SPICE Model File into AMS
- Create a Test Circuit
- Simulate the Test Circuit

We will provide the steps and an example project which you can use to practice running the process. This project folder can also be found in `<AMS installation path>\SDD_HOME\sim\systemvision\tutor\`. Copy the folder SPICE_import to your working directory.

Estimated time to complete: 30 to 45 minutes

Prerequisites: Installation and licensing of HyperLynx AMS and HyperLynx Advanced Solvers

Included Files

Data.zip

Files for lab

SPICE_model_import_and_simulate.docx Instructions for Lab

Description

SPICE simulator tools include schematic capture and waveform viewer with enhancements and models for improving the simulation of analog circuits. Its graphical schematic capture interface allows you to probe schematics and produce simulation results. Our goal in this lab is to take a previously existing SPICE model file and import it and simulate this in HyperLynx AMS.

There are several ways to import SPICE models into AMS depending on what needs to be imported. This section shows how to import a SPICE model from a file (.MOD extension) and run a time domain simulation.

Directions

Download Data.zip for the lab files.

Open the Tutorial Project

The first step for simulating a design is to open the project.

1. Open the tutorial.
2. Download and extract “Data.zip” to a working folder of your choosing.
3. In AMS, select the **File > Open > Project** menu item, browse into the copied folder, and open the SPICE_Import.prj file located in the extracted SPICE_import folder. If asked to automatically update this project to your version of AMS, click **Yes**.
4. Ensure that the AMS license is checked out. **Select Setup->Settings->Licensing** and check the AMS license.

Import SPICE Model from a File

1. On the AMS toolbar click the **Model and Symbol Wizard button** .
2. In the Model and Symbol Wizard:
 - a. On the Select Source form, in the “Select the model type or the data source for the model” area click SPICE and then click **Next**.
 - b. On the Select/Create Model form, to the right of the Spice File Name box, click the **Browse** button (...) and click the SPICE File popup menu item. In the project folder, open the Browse to the folder, which is located where you copied these tutorial files.
 - c. Open the file .\SPICE_Models_From_Web\SPICE_OpAmp_Mod_TI\OPA27.MOD and click **Next**. This is an OP27 op amp model from the Texas Instruments (TI).
 - d. On the Select/Create Symbol form, for the Symbol Graphics setting, click Generic Box.
 - e. Click **Finish**.
 - f. In the Save Model(s) & Mapping dialog set the Save to Location list choose Local Project and click **OK**. The symbol is added to the local project library and opened in a new window.

Edit New Symbol

You now have a working op amp and symbol for your design. However, the default placement of the symbol pins is not convenient for wiring in a schematic.

The pins for this op amp (and the other op amps you will use in the exercise) have the following assignments:

Pin 1: non-inverting input
 Pin 2: inverting input
 Pin 3: positive supply voltage
 Pin 4: negative supply voltage
 Pin 5: output

1. Ensure the **Grid Snap On/Off** button  is On
 Ensure the **Grid Display On/Off** button  is On

Figure 1 – op amp symbol changes

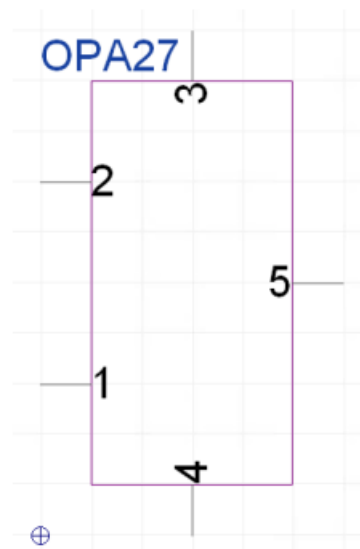

2. Right-click pin 5 (the line next to the number 5) and click the **Mirror** popup menu item.
3. Drag the pin to the right side of the symbol (solid) box and place it halfway between the top and bottom edges of the symbol box.
4. Right-click pin 4 and click the **Rotate** popup menu item.
5. Drag the pin to the bottom of the symbol box and place it halfway between the left and right edges of the symbol box.
6. Right-click pin 3 and click **Mirror**. Then right-click and click the **Rotate** popup menu item.
7. Drag the pin to the top of the symbol box and place it halfway between the left and right edges of the symbol box.
8. Drag pin 1 to two grid points above the bottom of the symbol box keeping it on the left side.

9. Drag pin 2 to two grid dots below the top of the symbol box keeping it on the left side. The symbol should look like Figure 1. As we are interested only in simulating (and not symbol aesthetics), we will not modify the symbol any further.
10. **Close** the OPA27.1 symbol window and **Save** when prompted.

Create a Test Circuit

1. Select **File > New > Schematic** to create a new schematic. You can give the schematic a new name, or just use the default name, Schematic1.
2. Click the **Simulation > Search/Place Symbols** menu item.
3. Expand the (Current Project) category and SPICE_import subcategory.
4. Place the new OPA27 symbol in the schematic.
5. On the Simulation toolbar, use the SPICE symbol buttons to complete the schematic as shown.



Figure 2 - Op amp test circuit

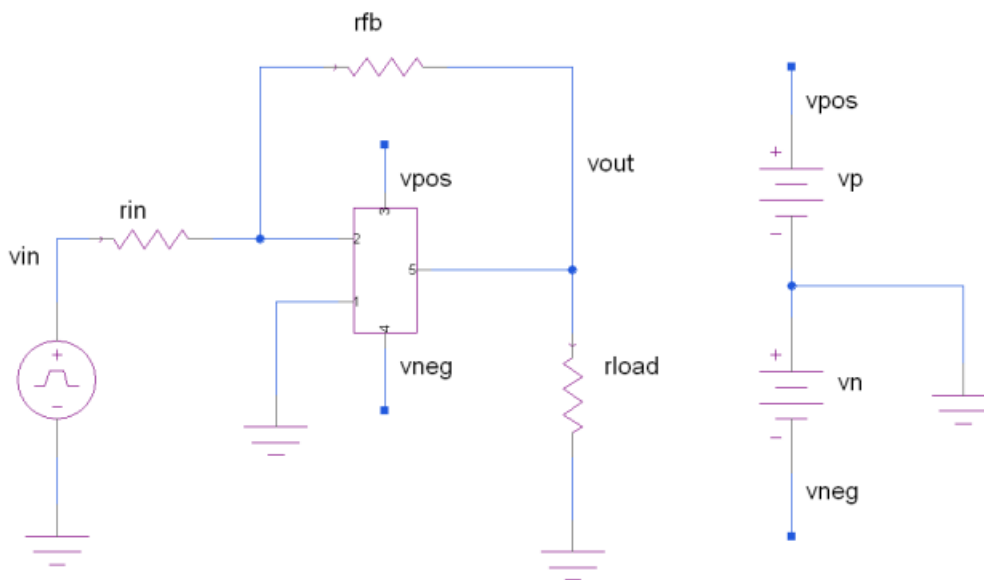

6. Set the component parameters as follows (ignore case differences):

Rin: Value = 10K

Rfb: Value = 5K

Rload: Value = 100K

vp: DC = 12.0

vn: DC = -12.0

6 Importing SPICE Models

V_PULSE:

T_RISE = 1 MS

T_FALL = 1 MS

T_WIDTH = 5 MS

T_PERIOD = 10 MS

V_FINAL = 5.0

V_INITIAL = -5.0

Note: The op amp power nets are connected to the DC sources by net name. Be sure to name these nets for both the op amp and the sources as shown in the figure (i.e. vpos and vneg).

7. We will run a time domain simulation for 20ms. First, we will want to go to **Simulation > Simulate**.

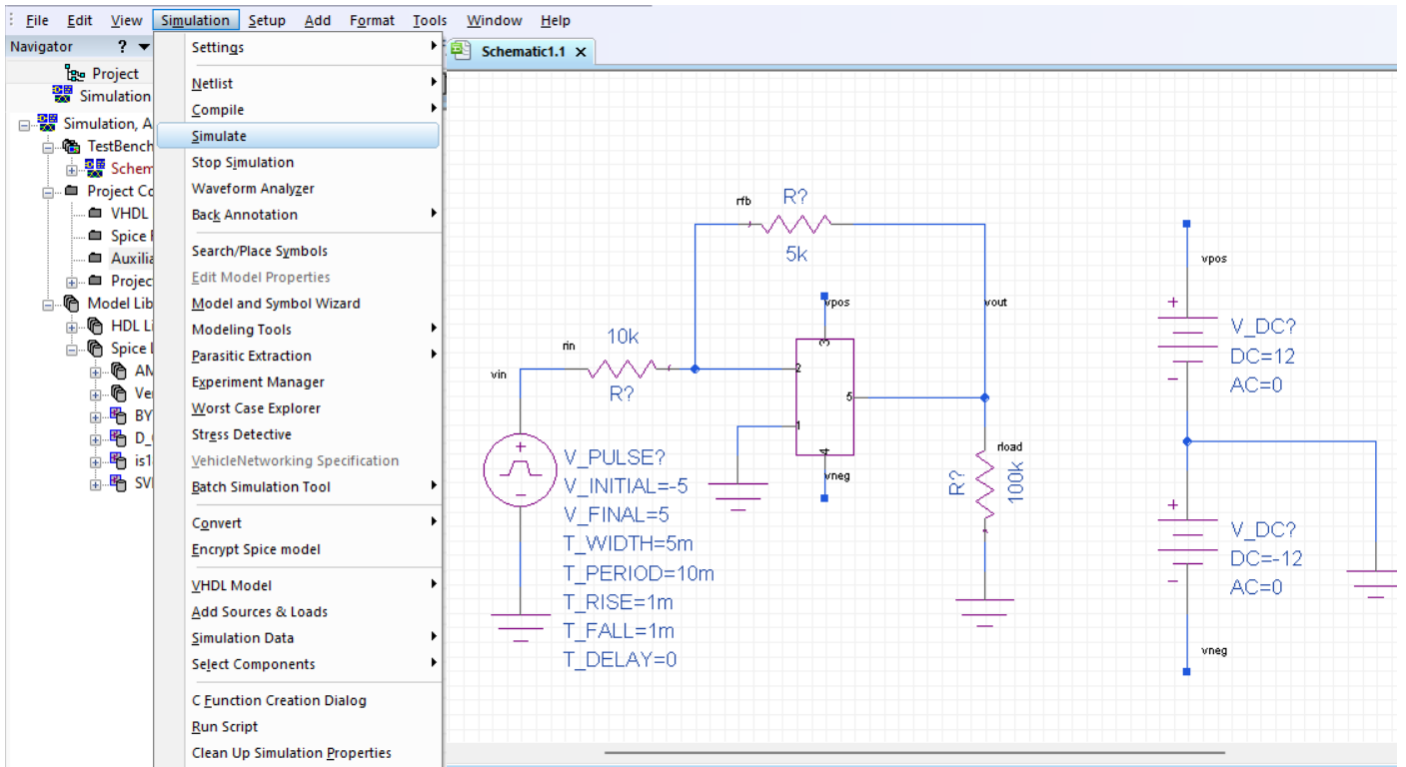

8. Enable Time Domain Analysis and set the end time for 20m.

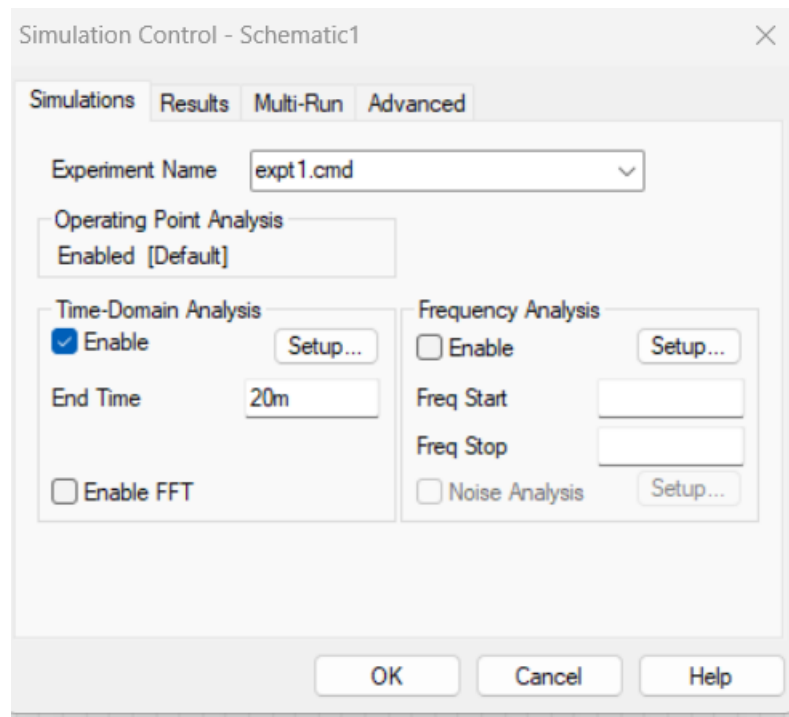

9. The waveform analyzer should pop up, and we can analyze the waveforms by either double clicking the waveform from the Waveform List or dragging and dropping a waveform from the Waveform List onto the waveform display window.

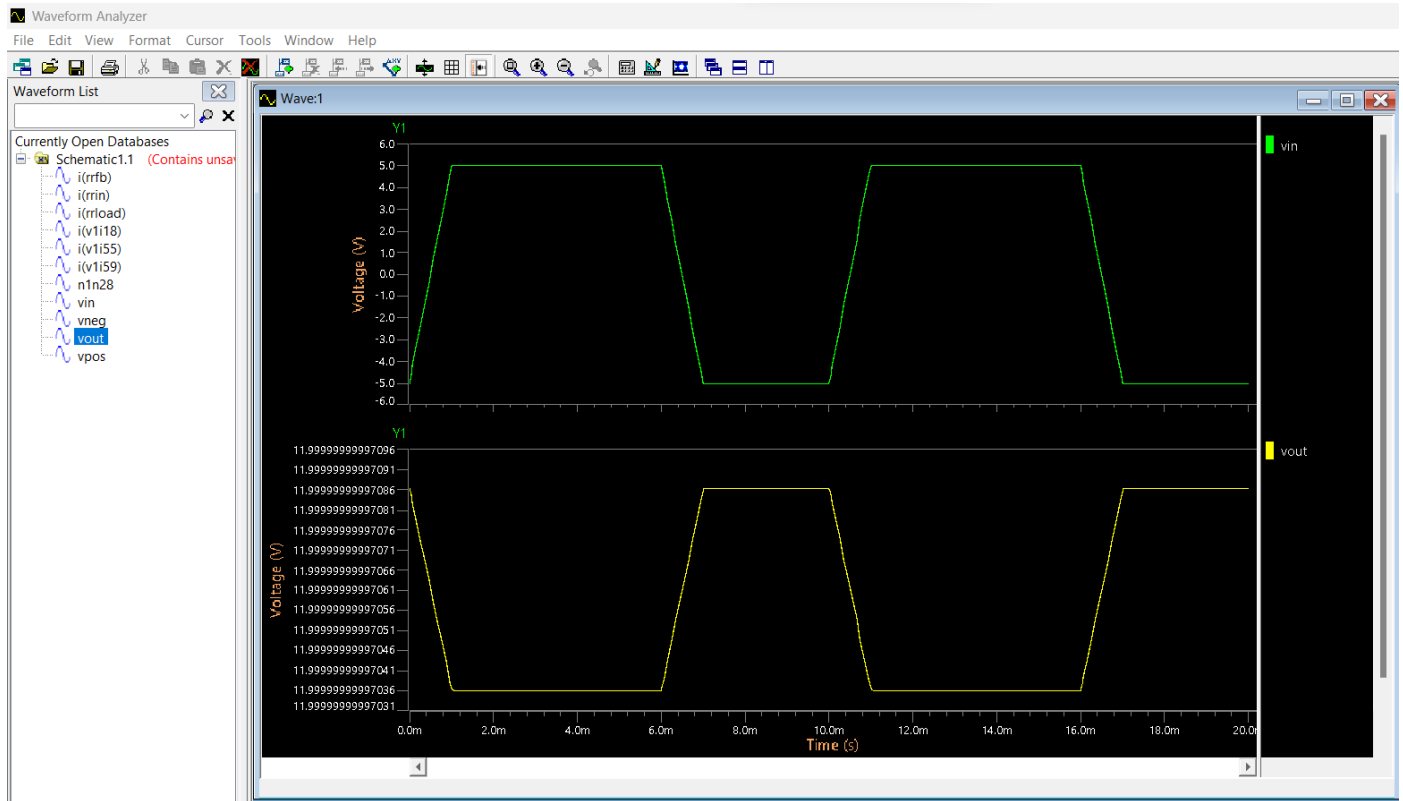

Conclusion

We have imported a SPICE model file and performed a time domain analysis.